

Autor H.Bollig

Erstellt: 06.01.2022

SSI2144 Synth - Voice
Synthesizer mit SSI2144 und PIC16F1765

Version : 1.0

Bl. Nr 1

Bl. 5

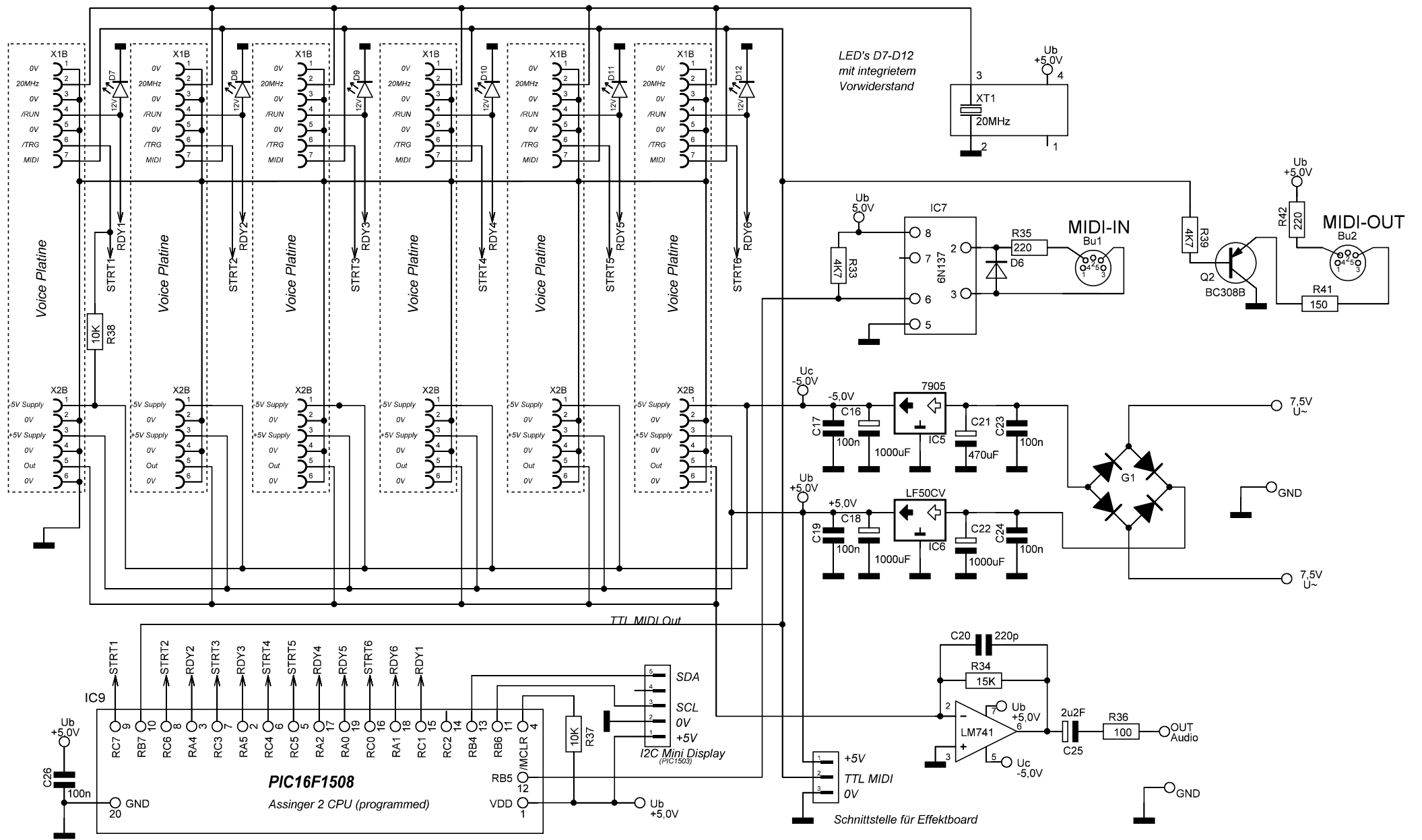

Autor H.Bollig
Erstellt: 06.01.2022

SSI2144 Synth - Mainboard mit Assinger 2 CPU
Synthesizer mit SSI2144 und PIC16F1765

Version : 1.1

Bl. Nr 2
Bl. 5

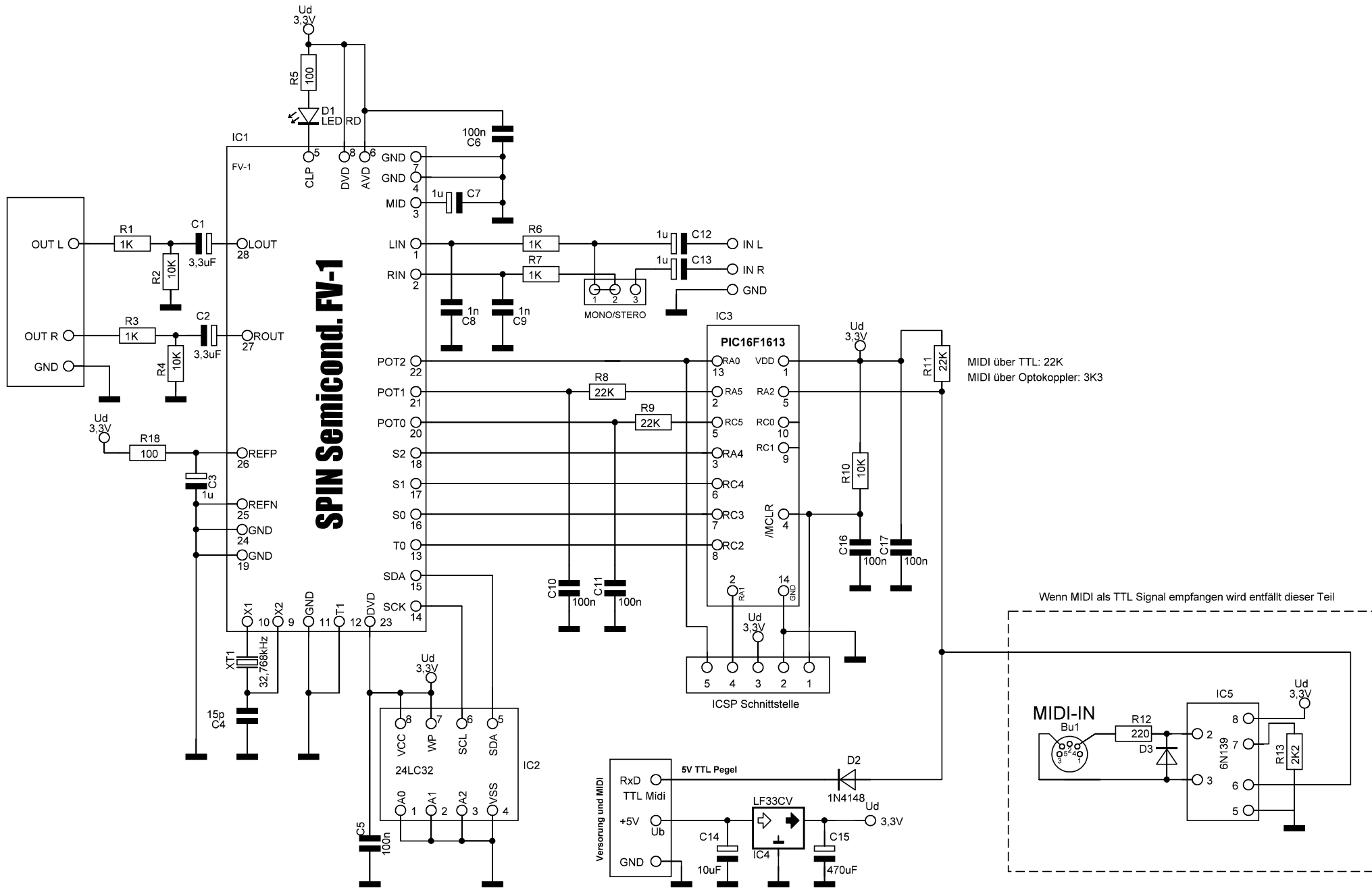

Autor H.Bollig

Erstellt: 06.01.2022

Midi FV1 - Effekt Borad

Ansteuerung FV-1 Chip mit PIC16F1613

Version : 1.0

Bl. Nr 3

Bl. 5

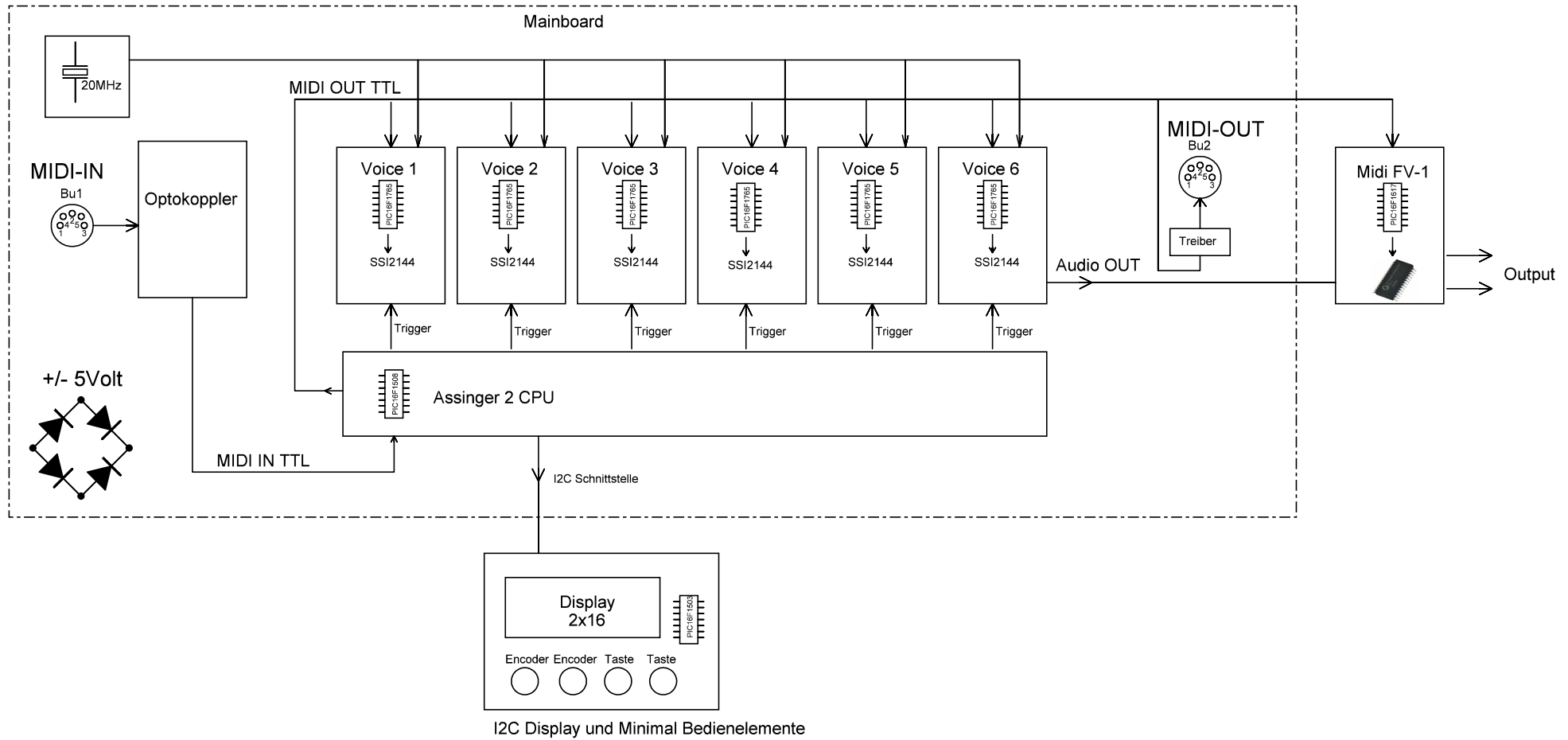

Autor H.Bollig

Erstellt: 06.01.2022

Synth Blockschaltbild

Synthesizer mit Assinger 2, Voice SSI2144 / PIC16F1765

Version : 1.0

Bl. Nr 4

Bl. 5

Stückliste Voice

C1□ = 100n
 C2□ = 100u
 C3□ = 470n
 C4□ = 100n
 C5□ = 220n
 C6□ = 47u
 C7□ = 100n
 C8□ = 560p
 C9□ = 6,8n
 C10□ = 6,8n
 C11□ = 6,8n
 C12□ = 270p
 C13□ = 1u
 C14□ = 100n
 C15□ = 100n

 IC1□ = PIC16F1765
 IC2□ = SSI2144
 IC3□ = MC33079

 Q1□ = BC308B
 Q2□ = BC308B
 Q3□ = 2N5461

 R1□ = 10K
 R2□ = 82K
 R3□ = 10K (1%)
 R4□ = 20K
 R5□ = 5K6
 R6□ = 10K
 R7□ = 27k
 R8□ = 27K
 R9□ = 22K
 R10□ = 220
 R11□ = 330
 R12□ = 12K
 R13□ = 22K
 R14□ = 39k
 R15□ = 10K
 R16□ = 1K
 R17□ = 10K
 R18□ = 220
 R19□ = 10K
 R20□ = 10K
 R21□ = 20K
 R22□ = 220
 R23□ = 22K (1%)
 R24□ = 10K
 R25□ = 3K9

 VR1□ = 5K
 VR2□ = 2K2

Stückliste Mainboard

Bu1□ = DIN-Buchse 5pol
 Bu2□ = DIN-Buchse 5pol

 C16□ = 1000uF
 C17□ = 100n
 C18□ = 1000uF
 C19□ = 100n
 C20□ = 220p
 C21□ = 470uF
 C22□ = 1000uF
 C23□ = 100n
 C24□ = 100n
 C25□ = 2u2F
 C26□ = 100n

 D6□ = 1N4148
 D7□ = 12V
 D8□ = 12V
 D9□ = 12V
 D10□ = 12V
 D11□ = 12V
 D12□ = 12V

 G1□ = BY

 IC5□ = 7905
 IC6□ = LF50CV
 IC7□ = 6N137
 IC9□ = PIC16F1508

 LM741□ =

 Q2□ = BC308B

 R33□ = 4K7
 R34□ = 15K
 R35□ = 220
 R36□ = 100
 R37□ = 10K
 R38□ = 10K
 R39□ = 4K7
 R41□ = 150
 R42□ = 220

 XT1□ = 20MHz

Stückliste Midi FV-1

Bu1□ = DIN-Buchse 5pol
 C1□ = 3,3uF
 C2□ = 3,3uF
 C3□ = 1u
 C4□ = 15p
 C5□ = 100n
 C6□ = 100n
 C7□ = 1u
 C8□ = 1n
 C9□ = 1n
 C10□ = 100n
 C11□ = 100n
 C12□ = 1u
 C13□ = 1u
 C14□ = 10uF
 C15□ = 470uF
 C16□ = 100n
 C17□ = 100n

 D1□ = LED RD
 D2□ = 1N4148
 D3□ = 1N4148

 IC1□ = FV-1
 IC2□ = 24LC32
 IC3□ = PIC16F1613
 IC4□ = LF33CV
 IC5□ = 6N139

 R1□ = 1K
 R2□ = 10K
 R3□ = 1K
 R4□ = 10K
 R5□ = 100
 R6□ = 1K
 R7□ = 1K
 R8□ = 22K
 R9□ = 22K
 R10□ = 10K
 R11□ = 22K
 R12□ = 220
 R13□ = 2K2
 R18□ = 100

 XT1□ = 32,768kHz

Autor H.Bollig

Erstellt: 06.01.2022

Stücklisten Synthesizer mit SSI2144 und PIC16F1765

Version : 1.0

Bl. Nr 5

Bl. 5